



DOMOTICS
READY



REMOTE
CONTROL



MANUAL
OPERATION

FOREST DS-XL® Series

The DS-XL® Series is designed to create visual impact and provides superior functionality and ease of use to the end-user. Available in a manual operated system or motorized.

FOREST DS-XL®
DS-XL® LED
DS-XL® LED Motorized

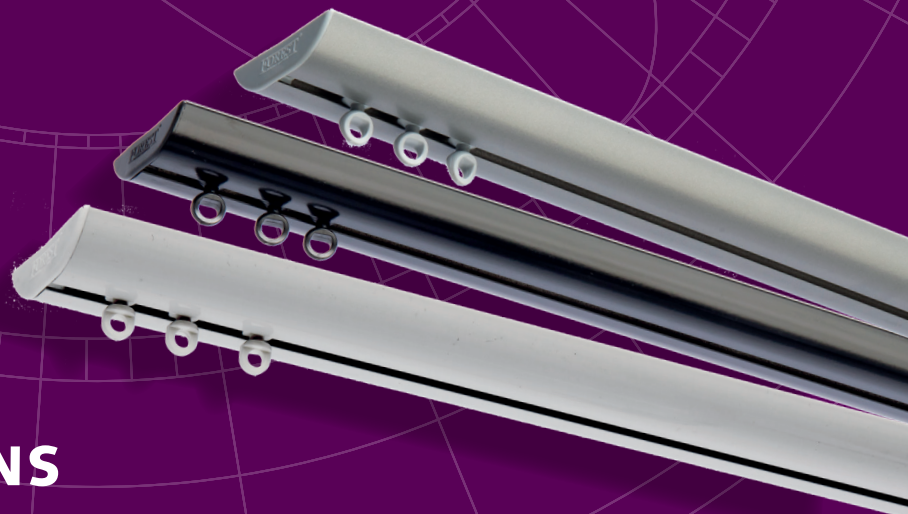

The world behind
YOUR CURTAINS

FOREST DS-XL®

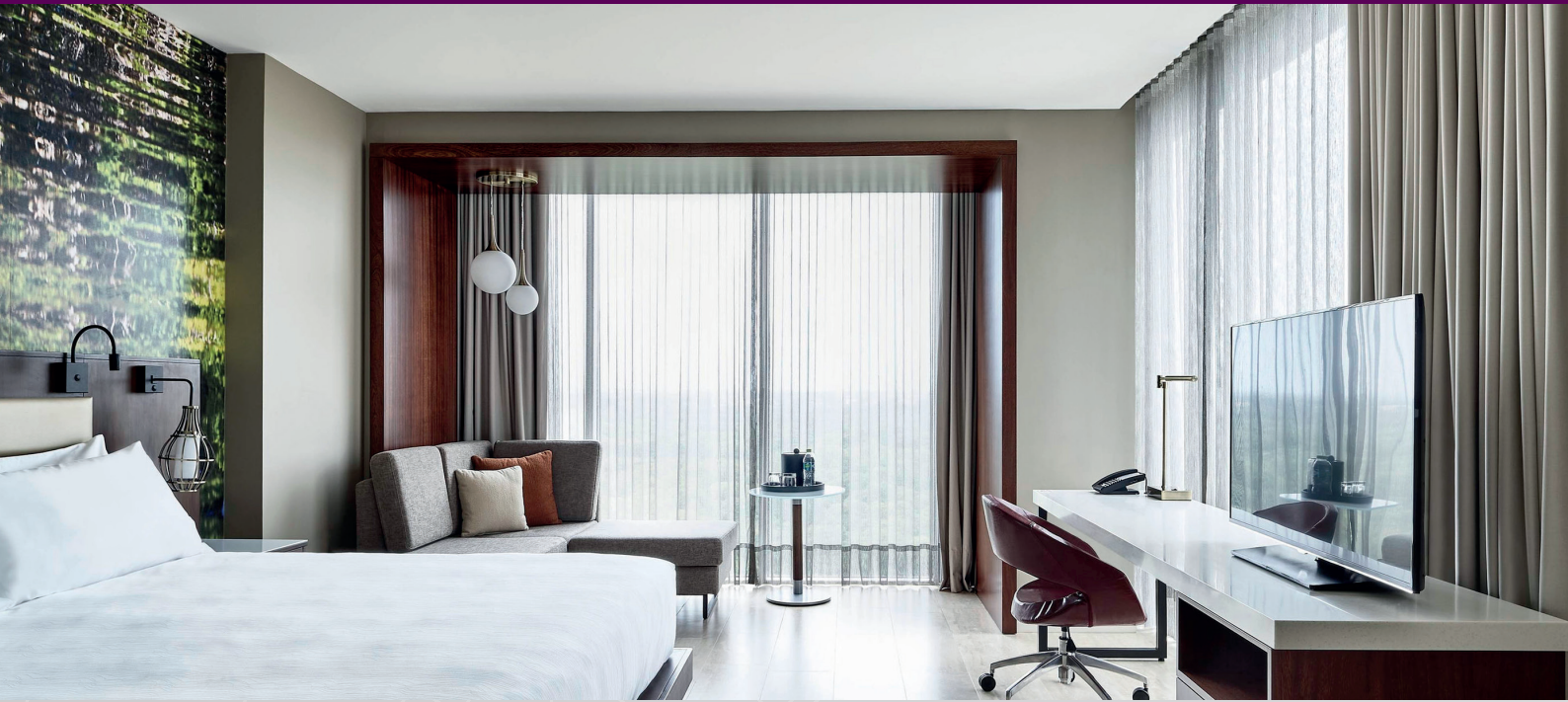

To complement the range of elegant curtain track systems, Forest has developed a decorative curtain track system, the DS-XL®. A unique and elegant curtain track that can be installed flush against the ceiling, or with pillar wall brackets.

The DS-XL® track system has been especially designed for use with our wave system, Forest Easyfold System. But it can also be made with regular pleated curtain headings. Thanks to its symmetrical profile the system is suitable for a blind installation against the ceiling, with click or swivel brackets.

PRODUCT INFORMATION

- Elegant and aesthetical hand drawn and corded curtain track system.
- For all types of medium weight draperies.
- Quick and easy installation.
- Ceiling brackets and wall brackets available.
- Heavy duty carriers - uv protected - for smooth and easy traversing.
- Colours available: white, silver or anthracite with matching components.
- Available length: standard stock size 6 meter (19,8")
- Especially designed for use in combination with Forest Easyfold System.

FOREST EASYFOLD® SYSTEM

Opt for a regular pleated heading or choose for a more dramatic effect for the Forest Easyfold® wave system. Our wave system is designed so that the curtains maintain their folding effect from the moment they are dressed.

- Easyflex with pockets on the heading tape, allowing for a flexible positioning of the hooks, in combination with Easyflex carriers and Easyflex hooks.
- Easywave with pockets on the heading tape, allowing for a flexible positioning of the hooks, in combination with rotating Easywave carriers and single endhooks.
- Easysnap with metal snaps on the heading tape, allowing for a fixed wave distance, in combination with Easyfold base carriers.

FOR USE IN

Hotels, offices, residences, boats, campers, planes or anywhere an efficient and elegant track system is required for curtains and drapes.



Easyflex tape application on DS-XL® track



PROFILE

- Shown actual size 1:1
- Weight 480 gr/mtr
- Aluminium extrusion
- Size 60 x 15 mm
- Colours available: white, silver or anthracite.

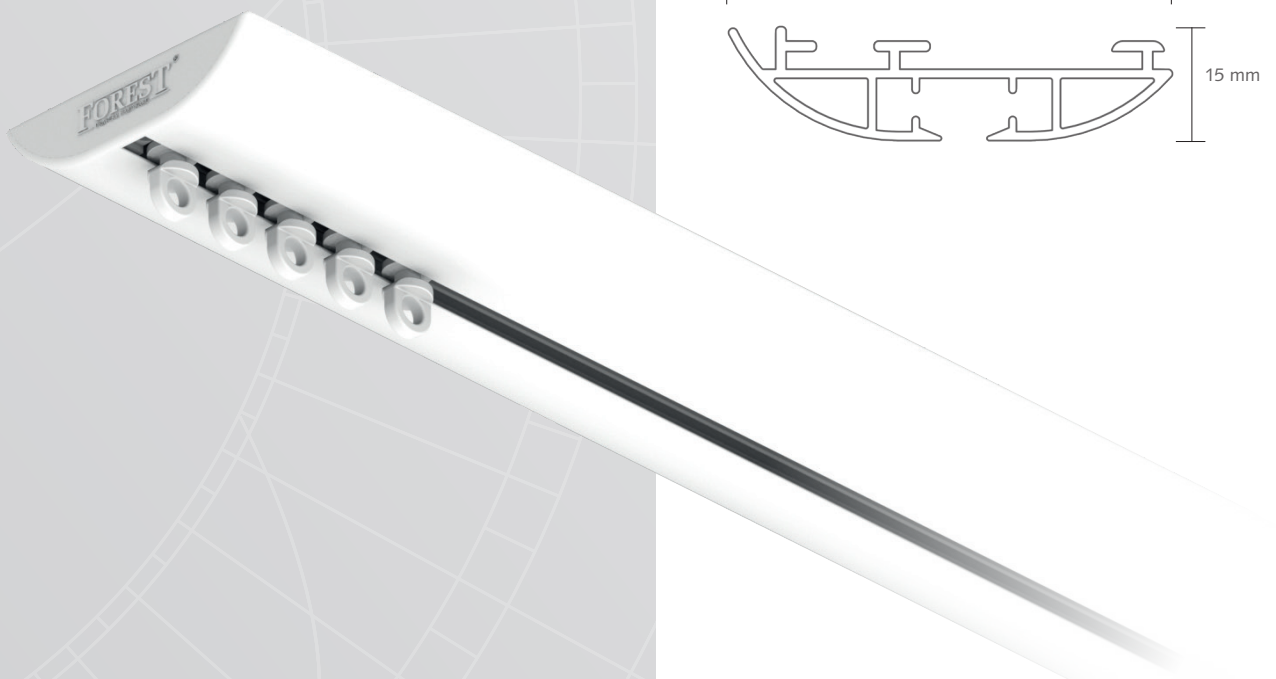
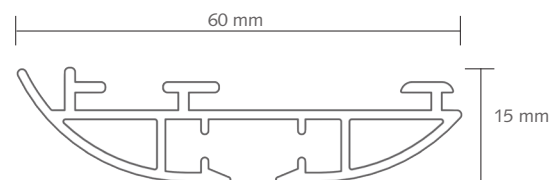

FOREST DS-XL® LED / Motorized

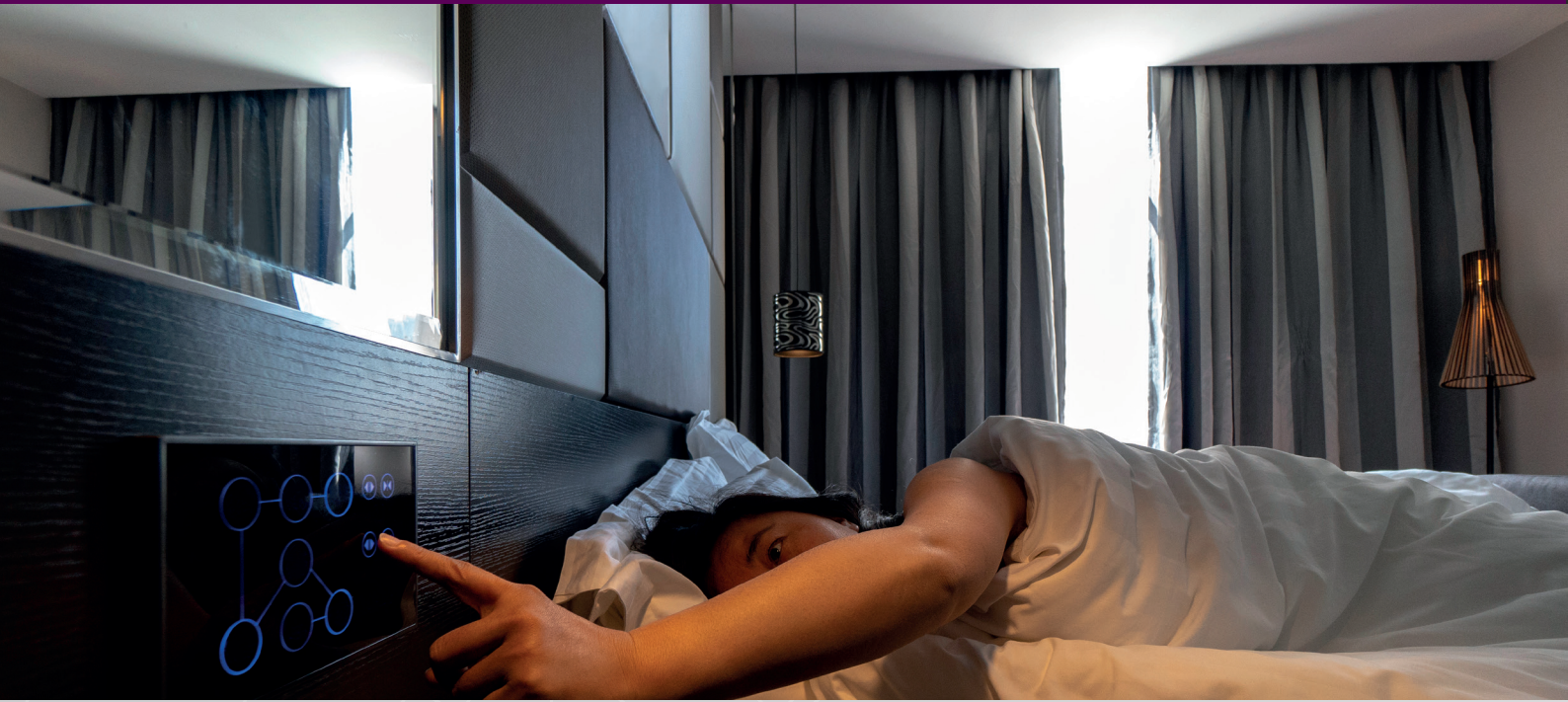

This unique drapery system combines a stylish design with a unique way of lighting. Many designers will work with a lighting plan with three levels: High, especially if the ceiling is vaulted or has been finished with a special material; medium, which includes wall sconces; and low, which means floor lamps and other small lights. Our DS-XL® LED is the solution for a lighting plan on a higher level, integrating our track to create an overall glow on the ceiling.

The DS-XL® LED is an elegant system for all types of medium weight draperies. Available length up to 6 meter in 2 colours: timeless white and in a stylish anthracite finish, making it suitable to fit in every design. It also offers the possibility to illuminate the backside and/or the curtain track itself enabling a higher level of privacy.

SUSTAINABLE LIGHTING

Traditional ways of lighting are very wasteful. Most of the power is wasted in the form of heat. This is why there has been a big push to change the environmental impact of lighting. Another benefit of LED lighting is sustainability and eco-friendliness. The system doesn't use toxic chemicals and it can last for years. It has a life span of approximately 30.000 hours.

NEW: DS-XL® LED MOTORIZED TRACK SYSTEM

The DS-XL® LED Motorized track system is the latest innovation of the Forest Design Series. This brand new drapery system is designed to create visual impact and provides superior functionality and ease of use to the end-user. Controlling the curtains and integrated LED-lighting by remote control or building automation system guarantees a unique experience of atmosphere and comfort in any room.

PRODUCT INFORMATION

- Designer track for lighting and curtain track combined.
- Especially designed for Forest Easyfold application.
- Easy electrical installation by means of clickable connectors.
- Ceiling brackets and wall brackets available.
- One LED strip or two led strips for extra luminosity.
- LED Colour temperature: warm white 3000K
- Low energy consuming LED strip, eco friendly.
- Dimmable LED strips (120 LED's per meter)
- LED Lifespan of 30.000 hours.
- No soldering, clickable components for easy installation without the need for an electrician.
- Power: 15 watt/mtr (4.6 Watt/ft)
- Energy label A+
- Colours available: white and anthracite.
- The DS-XL® LED Motorized system can be integrated into any building automation system.
- The motorized track system can be installed onto all Forest Motorized systems like; Shuttle® and FMS®.



FOR USE IN

Hotels, offices, residences, boats and yachts, showrooms, business meeting rooms, conference centers or anywhere an efficient and elegant track system is required for curtains and drapes.

PROFILE

- Shown actual size 1:1
- Size LED 61 x 20 mm
Size Motorized 66 x 25 mm
- Weight LED 580 gr/mtr
Weight Motorized 675 gr/mtr
- Aluminium extrusion
- Colours available: white or anthracite

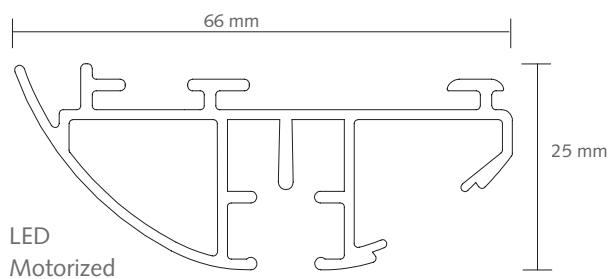
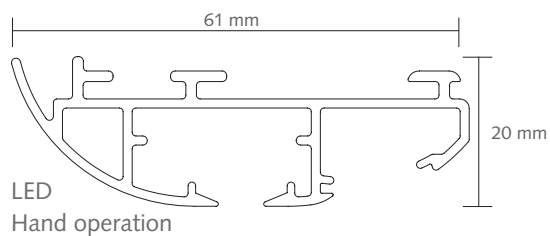

FOREST EASYFOLD® SYSTEM

Opt for a regular pleated heading or choose for a more dramatic effect for the Forest Easyfold® wave system. Our wave system is designed so that the curtains maintain their folding effect from the moment they are dressed.

- Easyflex with pockets on the heading tape, allowing for a flexible positioning of the hooks, in combination with Easyflex carriers and Easyflex hooks.
- Easywave with pockets on the heading tape, allowing for a flexible positioning of the hooks, in combination with rotating Easywave carriers and single endhooks.
- Easysnap with metal snaps on the heading tape, allowing for a fixed wave distance, in combination with Easyfold base carriers.



FOREST DS-XL® LED / Motorized

COMPATIBLE WITH



www.amx.com

In Concert Partner



www.knx.nl

KNX partner



www.z-wave.com

Z Wave alliance partner



www.crestron.com

I2P partner



SMARTHOMES

www.smart-homes.nl

Smart homes partner

DS-XL® LED Motorized track system is compatible with many other Building Automation systems, thanks to its modular construction. A competitive advantage over the motorized drapery systems in the world!

CONTROL OPTIONS

Our broad range of controls make finding a fit for your home even easier; controlling the curtains by hand, remote or even by building automation system. With the remote you can control the curtains and light in any position you like. Controlling the motorized curtain system by your smartphone or tablet, you can create and schedule customized room scenes that allow your curtains to operate on their own throughout the day.



FOREST DIAMOND SENSE REMOTE

15 Channel Remote control, possibility to control up to 15 systems individually and in group by integrated timer function or manual. Auto-On mode, when holding hand above it, the integrated LED light will automatically come on. Radio control, range up to 30 meters. Including magnetic wall support.



BUILDING AUTOMATION

The DS-XL® LED Motorized track system can be connected to any Building Automation system, by relay control.

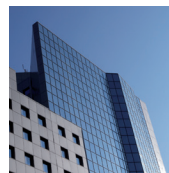









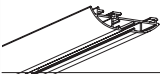
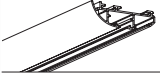
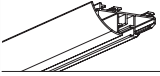
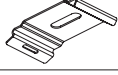
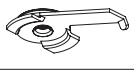
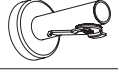

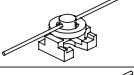
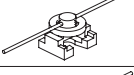
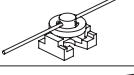



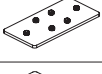
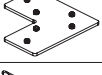











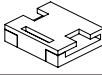

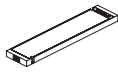
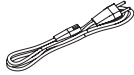
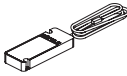

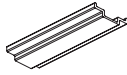
HOTEL CONTROL

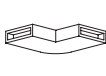
The DS-XL® LED Motorized track system can be connected to any Hotel Automation system, by relay control.

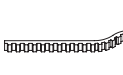
OTHER CONTROL OPTIONS

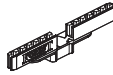
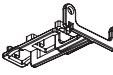
Z-Wave receivers and controls and switch control are available on request.

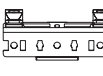
DS-XL	DS-XL LED	DS-XL LED MOTO-RIZED	ARTICLE	PACKING UNIT		ART.NR
●			 DS-XL TRACK, 6 mtr (19"8")	24mtr/bundle	white silver anthracite	3916101600 3916103600 3916106600
	●		 DS-XL LED TRACK	6mtr/bundle	white anthracite	5917501600 5917506600
		●	 DS-XL LED MOTORIZED TRACK, 6 mtr	mtr	white anthracite	5915501600 5915505600
●	●	●	 DS-XL KLICK CEILING BRACKET	100/box		3918301000
●	●	●	 DS-XL CEILING SWIVEL BRACKET	100/box	white anthracite	3818200230 3818205230
●	●	●	 DS-XL/PS WALL BRACKET 9 CM	5/box		3820001018
●	●	●	 DS-XL END STOP	100/box		3916001000
●	●	●	 ECONOMY CARRIER SMALL	500/box	white anthracite	3910101000 3910106000
●	●	●	 FES EASYFOLD BASE 60%	500/roll	white black	4812001060 4812006060
●	●	●	 FES EASYFOLD BASE 80%	500/roll	white black	4812001080 4812006080
●	●	●	 FES EASYFOLD BASE 100%	500/roll	white black	4812001100 4812006100
●	●	●	 FES EASYWAVE CARRIER 60%	1000/roll	white black	4812101060 4812106060
●	●	●	 FES EASYWAVE CARRIER 80%	1000/roll	white black	4812101080 4812106080
●	●	●	 EASYFLEX HOOK	500/roll	white black	4812801000 4215806000
●	●	●	 EASYFLEX ENDBOOK TRANSPARENT	1000/box		4812801010
●	●	●	 DS-XL TRACK CONNECTOR STRAIGHT	15/box		3916401000
●	●	●	 DS-XL TRACK CONNECTOR 90 DEGREES	15/box		3916401001
●			 DS-XL ENDCAP	20/box	white silver anthracite	3916101000 3916103000 3916106000
●			 DS-XL ENDCAP CORDED	20/box	white silver anthracite	3916201000 3916205000 3916206000
	●		 DS-XL LED ENDCAP	20/box	white anthracite	5916501000 5916506000
	●		 DS-XL LED ENDCAP FLAT	20/box	white anthracite	5916501002 5916506002
●			 DS-XL / CKS CORD CONNECTOR	100/box	white regular	1530301000
●			 CORD 3 MM ON ROLL	200mtr/roll	white	3830401000
●			 CKS/CCS TENSION PULLEY	25/box		1030501000

DS-XL	DS-XL LED	DS-XL LED MOTO-RIZED	ARTICLE	PACKING UNIT	ART.NR
●			 BS CORD/CHAIN WALL MOUNT SAFETY BOX SINGLE	25/box	3645702000
●			 CORD/CHAIN WEIGHT DESIGN	10/box	3030701000
	●	●	 DS-XL LED STRIP 3000K/24V	6mtr/bundle	5917503015-R1
	●		 DS-XL LED CONNECTOR STRAIGHT	10/box	5917502400
	●	●	 DS-XL LED CONNECTOR CABLE	1/box	black (200cm/24v) 5917502420
	●	●	 DS-XL LED POWER TRANSFORMER	1/box	black 40w 24v black 90w 24v 5917522440 5917522490
	●	●	 DS-XL LED POWER SUPPLY CABLE, black	1/box	(200cm/230vac) eu (200cm/230vac) uk (200cm/110vac)us 5917520020 5917520021 5917520022
	●	●	 DS-XL LED DIMMER/RECEIVER 4 CHANNEL	1/box	black 60w/24v 5917532460
	●	●	 DS-XL LED REMOTE CONTROL 4 CHANNEL	1/box	black 12v/24v 5917532404
	●	●	 DS-XL LED STRIP OPAL - BACK	6mtr/bundle	5916509000
	●		 DS-XL LED STRIP OPAL - MIDDLE	6mtr/bundle	5916509001
	●	●	 DS-XL LED STRIP MOUNTING DEVICE	1/box	5916509999
	●		 DS-XL LED STRIP CONNECTOR 90 DEGREE	10/box	5917502490
		●	 DS-XL LED MOTORIZED MOTOR PULLEY, 6 mtr	1/box	white anthracite 5917011000 5917076000
		●	 DS-XL LED MOTORIZED RETURN PULLEY, 6 mtr	1/box	white anthracite 5917011100 5917016100
		●	 FMS TRANSPORT BELT, Toothed belt, to be installed inside the FMS Track	100mtr/roll	5105501000
		●	 FMS BELT CONNECTOR, Connects the Master Carrier with the transport belt	50/box	white silver anthracite 5103011500 5103013500 5103016500
		●	 MRS BELT CONNECTOR, Connects the Master Carrier with the transport belt	25/box	4805711500
●	●	●	 EASYFLEX PLASTIC 90 DEGREES MASTER CARRIER	25/box	white silver anthracite 3916701000 3916703000 3916706000
		●	 EASYFLEX MASTER CARRIER 90 DEGREES LEFT	15/box	4815351090
		●	 EASYFLEX MASTER CARRIER 90 DEGREES RIGHT	15/box	4815451090
		●	 CCS MASTER CARRIER BASE, Multifunctional - reversible arm - will go through curves	15/box	white silver 3015601000 3015603000
		●	 EASYFLEX CURVED ARM	15/box	white silver anthracite 5135901020 5135903020 5135906020